

ASPT-11e

eco Pressure Transmitter
Special OEM project



ASPT-11e Pressure Transmitter is developed to meet the growing water industry which demands for economical and reliable solution

ASPT-11e Pressure Transmitter is widely used in frequency pumps, water treat plants, compressors and more. Specialized with waterproof hammer, good electrical properties and long-term stability, makes the **ASPT-11e** Pressure Transmitter acceptable in the market and can directly replace a variety of similar imported products.

Features

- ✓ The use of advanced ceramic sensor core
- ✓ Varied Pressure ranges
- ✓ Varied Electrical Output
- ✓ Compact, Low Cost
- ✓ Good Electrical properties
- ✓ Proof against water hammer
- ✓ Long-term Stability

Specification

Pressure Range: 0~ 1 Bar onwards upto 0~40 Bar
Accuracy: +/-1%FS (compact version) & +/-0.5% FS
Overload Pressure: 2X Rated Pressure
Output: 0.5 ~ 4.5 VDC | Supply: 5 VDC
0 ~ 5VDC | Supply: 10-28 VDC
4 ~ 20 mA | Supply: 10-28 VDC
Operating Temperature: -40 ~ 125 °C
Measured Media Temperature: 0 ~ 85 °C
IP Rating: IP67

Dimensional Drawing

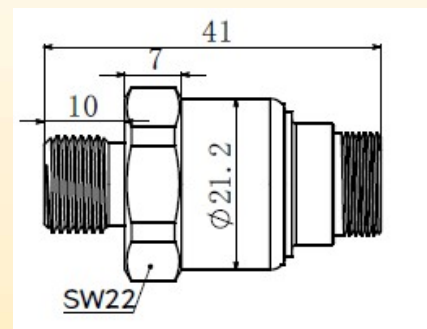
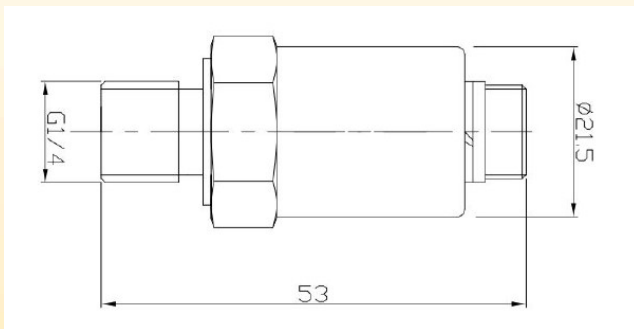

Electrical Connection:

Output	4~20mA	0~5V	0.5~4.5V
Power supply+	1.red	1.red	1.red
Power supply-		2.black	2.black
Signal+	3.black	3.white	3.white

ORDERING GUIDE

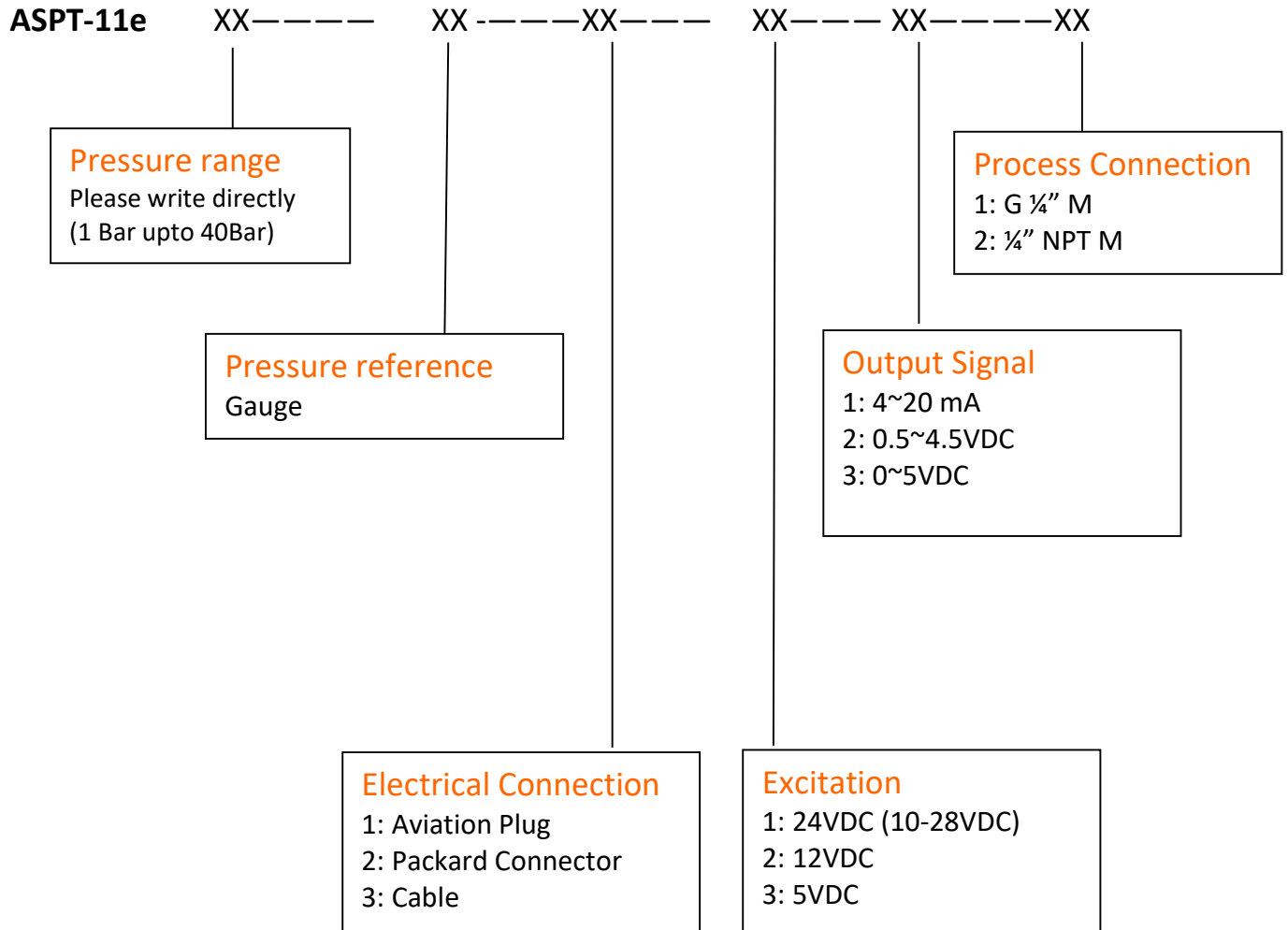

Eg: ASPT-11e-10B-G-1-1-1-1
(0 to 10 Bar G, Aviation Plug, 4-20 mA, G ¼" M)

- Due to continuous development of our products technical information are subject to change
- Contact Factory for custom configuration not shown

